

2000 SERIES

WATER, HOT OIL & AIR

SHOCK & VIBRATION
RESISTANT

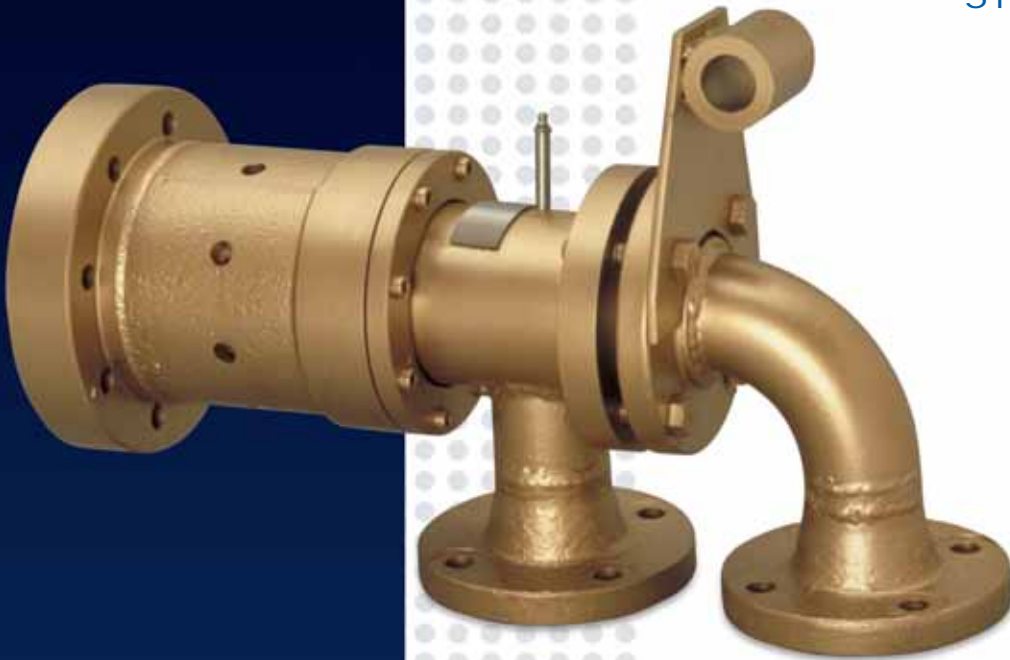

Operating Parameters

MEDIA

Water, Hot Oil, Air

PRESSURE*

150 PSI (Water), 100 PSI (Air & Hot Oil)

TEMPERATURE*

375° F (Water), 550° F (Hot Oil)**

SPEED*

500 RPM

CONNECTIONS

2" to 4" ASA Flange

MATERIAL

Cast Iron Housing, Steel Shaft

CONFIGURATION OPTIONS

Mono Flow & Dual Flow Configurations Available

* See Performance Charts For Details

** Consult factory for applications exceeding 375° F

Features & Benefits

Heavy Duty Design

Designed with two ball bearings spaced to withstand radial and thrust loads.

No Leakage In Tough Applications

Compression springs in the 2000 Series provide even loading across the seal surfaces to maintain zero leakage even in low pressure applications.

Easy Maintenance

Designed with an integral flange that allows repairs without removing the housing from the machine.

Easy Mounting

The flange attaches directly to the machine journal, providing inherently concentric mounting, minimizing overhang, and partially relieving bearing load to increase service life.

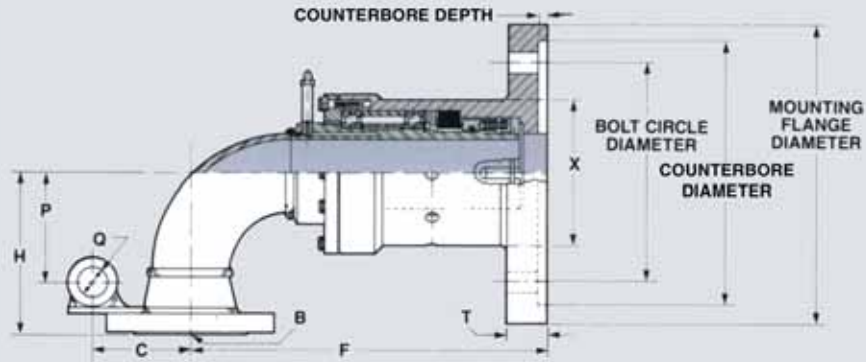

2000 SERIES ROTARY UNIONS • MONO FLOW (in.)

Nominal Pipe Size	Part Number	Repair Cartridge	B (3)	F	T	Mounting Flange Diameter	Bolt Circle Diameter	Flange Type	Counterbore		Bolt Hole Size	Number of Bolt Holes (4)	H	P	Diameter (X)	Diameter (Q)	C
									Diameter	Depth							
2	730747C	441781C	2	12-3/4	1-7/16	10	7-1/8	2	9.002 to 9.004	3/16	11/16	4	5-1/2	N/A	5-1/4	-	-
3	730841C	441845C	3	16-1/8	1-3/4	9-1/2	7-9/16	2	10.824 to 10.820		13/16	8	7-1/4	N/A	6-5/16	-	-
4	730842C	441846C	4	20-1/4	1-3/4	11-1/2	8-15/16	2	10.824 to 10.820		6	9-1/8	6-3/4	7-3/4	1/8	5-3/4	

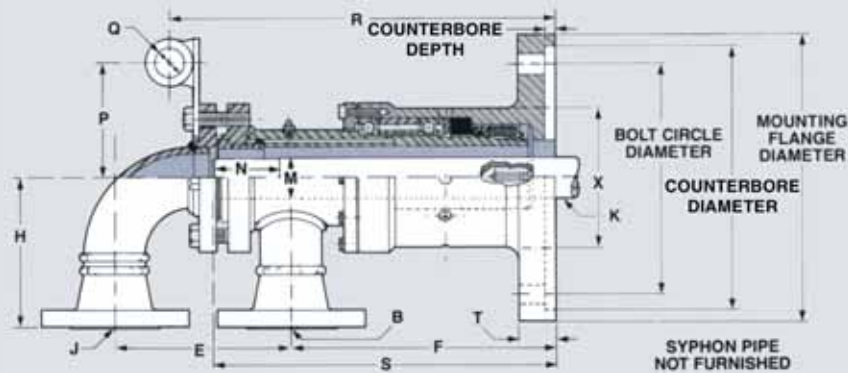

2000 SERIES ROTARY UNIONS • DUAL FLOW • WITH REVOLVING SYPHON (in.)

Nominal Pipe Size	Part Number	Repair Cartridge	B(3)	F	T	Mounting Flange Diameter	Bolt Circle Diameter	Flange Type	Counterbore		Bolt Hole Size	Number of Bolt Holes	H	P	Diameter (X)	Diameter (Q)	K(1)	M(2)	N	J(3)	S	E	R
									Diameter	Depth													
2	730843C	441847C	1-1/2	10	1-7/16	10	7-1/8	2	9.002 to 9.004	3/16	11/16	4	4-5/8	-	-	-	3/4	.991 to .997	4-1/4	1-1/2	13-3/8	6-5/8	N/A
3	730737C	441786C	2-1/2	12-1/2	1-3/4	9-1/2	7-9/16		9.002 to 9.004		11/16	8	7-1/8	5-1/2	6-1/4	1-3/8	1-1/2	1.865 to 1.871		2-1/2	16-1/4	8-3/8	18-1/4
4	730852C	441860C	2-1/2	15-3/8	1-3/4	11-1/2	8-15/16		10.820 to 10.824		13/16	6	7-1/8	6-1/8	7-3/4	1-3/8	2-1/2	2.801 to 2.807		2-1/2	19-3/8	8-7/8	21

- (1) Standard syphon pipe diameter.
- (2) Machined dimension to allow revolving syphon pipe to run concentrically with journal diameter to within .005" T.I.R.
- (3) 150 lb. ASA Flange.
- (4) Equally spaced.
- (5) Not applicable to this size joint.

Notes:

- 1. For heat transfer oil applications, consult factory
- 2. Other flange dimensions available. See previous page.
- 3. For dimensions on 5" - 6", consult factory

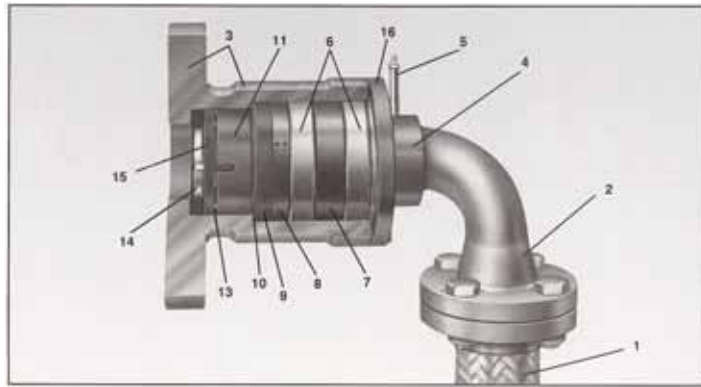

The unique design of this 2000 series flanged type rotary joint permits them to be used to introduce heating or cooling agents into rolls or cylinders in various types of machinery. Models are available to handle water, oil and other fluids in applications requiring sealing pressure to 150 psi, speeds to 500 rpm, and temperatures to 550°F. when specified.

- 1 FLEXIBLE HOSE** eliminates complex piping, allows adjustment of rolls without repiping. Allows rotary joint to "float" so as to avoid unnecessary strain on sealing surfaces. A flexible hose either rubber or metal — must always be used with rotary joints.
- 2 FLANGED INLET** elbow of steel is a 150 lb. ASA flange type.
- 3 FLANGED ROTATING HOUSING** prevents leakage under pressure and protects the internal parts for a long service life. The flanged housing attaches directly to the machine journal, providing inherently concentric mounting, minimizes overhang. The housing may rotate in either direction without causing back out problems.
- 4 STATIONARY SHAFT** is constructed of steel. It serves as a conduit for the fluid transfer from the flanged inlet into the revolving flanged housing.
- 5 LUBRICATION FITTING** located on the stationary shaft allows lubrication of the ball bearings while the rotary joint is in operation.
- 6 TWO SINGLE ROW, WIDELY SPACED BALL BEARINGS** for radial and thrust loads.

- 7 GREASE RING ASSEMBLY** of steel, ground and spaced for ball bearing load sharing for increased life.
- 8 DRAIN RING** is made of steel. It allows minute start-up leakage from entering the ball bearings.
- 9 SEAL RING** forms the primary rotating seal with the face ring. The seal ring is constructed of carbon graphite to provide a low friction, wear resistant surface.
- 10 GASKET** provides an effective seal between the housing and the fluid chamber.
- 11 THE FACE RING** constructed of hardened and tempered stainless steel mates with the seal ring to form the primary seal.
- 12 O-RING ELASTOMER (not shown)** of ethylene propylene for hot water applications. For higher temperature applications, a perfluoroelastomer is used.
- 13 COMPRESSION SPRINGS** apply an initial pressure between the face ring and seal ring to provide sealing for low pressure applications.
- 14 DRIVE COLLAR** keys the face ring and the shaft together to prevent rotation.
- 15 RETAINER RINGS** secure the internal components to the shaft.
- 16 FLANGE SECURES** the internal components within the flanged housing. This allows quick rotary joint repair and less machine downtime.

2000 & 9000 SERIES • BOLT & FLANGE DIMENSIONS				
Shaft I.D.	Minimum Bolt Circle		Maximum Flange Diameter (A)	Maximum Flange Thickness
	Bolt Circle (B)	Cap Screw Diameter		
2	7-1/8	5/8	10-7/8	1-7/16
3	7-9/16	5/8	13-1/2	1-3/4
4	8-15/16	3/4	14-7/8	2-1/16
5	11-9/16	1	16-1/4	2-3/4

*All dimensions in inches

Order Checklist

Supply the following information when ordering

- 1. Desired bolt circle
- 2. Bolt hole size
- 3. Number of bolt holes and spacing
- 4. Desired flange thickness
- 5. Flange O.D.
- 6. Pilot diameter and type
- 7. Pilot (length or depth)

2000 Series Shock Resistant Flange Mountings

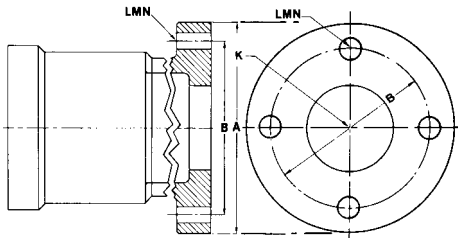

Flanged Housing Type 1

- A. Overall diameter
- B. Bolt circle diameter
- K. Rotary Union joint shaft thread size and direction
- L. Size of bolt holes
- M. Type and size of bolts
- N. Number of bolt holes required

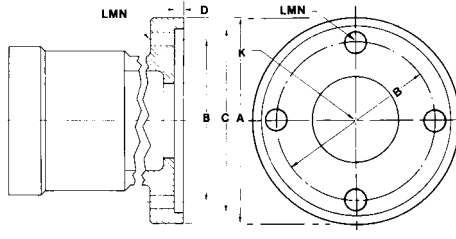

Flanged Housing w/ Counterbore Type 2

- A. Overall diameter
- B. Bolt circle diameter
- C. O.D. of journal for sizing counterbore diameter
- D. Counterbore depth
- K. Rotary Union joint shaft thread size and direction
- L. Size of bolt holes
- M. Type and size of bolts
- N. Number of bolt holes required

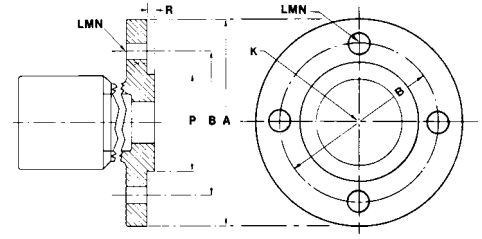

Flanged Housing w/ Pilot Type 3

- A. Overall diameter
- B. Bolt circle diameter
- K. Rotary Union joint shaft thread size and direction
- L. Size of bolt holes
- M. Type and size of bolts
- N. Number of bolt holes required
- P. I.D. of journal for sizing pilot diameter
- R. Pilot length

Performance Charts

2"

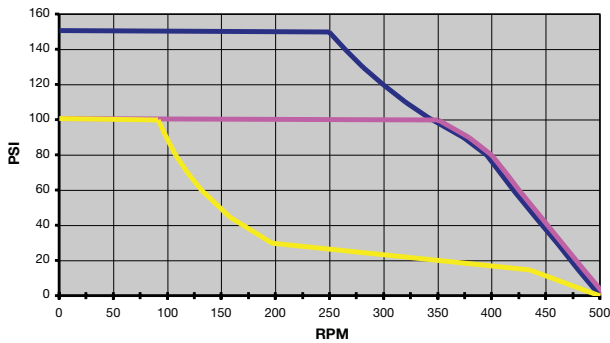

3"

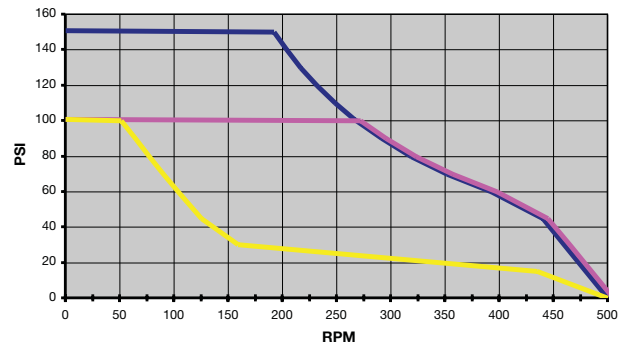

4"

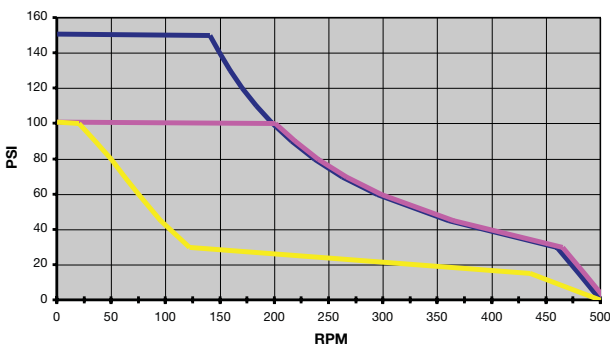

5"

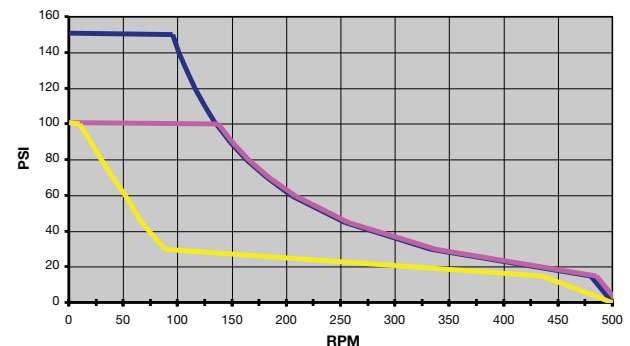

Water Oil Air